



# **AiP74LV165**

## **8-bit Parallel-in/Serial-out Shift Register**

### **Product Specification**

**Specification Revision History:**

<b>Version</b>	<b>Date</b>	<b>Description</b>
2022-12-A1	2022-12	New
2024-04-A2	2024-04	Add pin configurations of VQFN16



# Contents

<b>1、 General Description.....</b>	<b>1</b>
<b>2、 Block Diagram And Pin Description .....</b>	<b>3</b>
2.1、 Block Diagram .....	3
2.2、 Pin Configurations.....	4
2.3、 Pin Description.....	5
2.4、 Function table.....	5
<b>3、 Electrical Parameter .....</b>	<b>6</b>
3.1、 Absolute Maximum Ratings.....	6
3.2、 Recommended Operating Conditions.....	6
3.3、 Electrical Characteristics .....	6
3.3.1、 DC Characteristics 1 .....	6
3.3.2、 DC Characteristics 2 .....	7
3.3.3、 AC Characteristics 1 .....	8
3.3.4、 AC Characteristics 2 .....	9
<b>4、 Testing Circuit .....</b>	<b>11</b>
4.1、 AC Testing Circuit .....	11
4.2、 AC Testing Waveforms.....	11
<b>5、 Package Information .....</b>	<b>14</b>
5.1、 SOP16 .....	14
5.2、 SSOP16 .....	15
5.3、 TSSOP16.....	16
5.4、 VQFN16.....	17
<b>6、 Statements And Notes .....</b>	<b>18</b>
6.1、 The name and content of Hazardous substances or Elements in the product.....	18
6.2、 Notes .....	18



## 1、 General Description

The AiP74LV165 is an 8-bit parallel-load or serial-in shift register with complementary serial outputs (Q7 and  $\overline{Q7}$ ) available from the last stage.

Schmitt-trigger action at all inputs, makes the circuit tolerant for slower input rise and fall times.

### Features:

- Wide operating voltage: 1.0V to 5.5V
- 5.5 V tolerant inputs/outputs
- Power-down mode
- Specified from -40°C to +125°C
- Packaging information: SOP16/SSOP16/TSSOP16/VQFN16



## Ordering Information:

### Tube packing specifications:

Part number	Packaging form	Marking code	Tube quantity	Boxed tube quantity	Boxed quantity	Notes
AiP74LV165SA16.TB	SOP16	74LV165	50 PCS/tube	200 tube/box	10000 PCS/box	Dimensions of plastic enclosure: 10.0mm×3.9mm Pin spacing: 1.27mm
AiP74LV165VA16.TB	SSOP16	74LV165	80 PCS/tube	100 tube/box	8000 PCS/box	Dimensions of plastic enclosure: 6.2mm×5.3mm Pin spacing: 0.65mm
AiP74LV165TA16.TB	TSSOP16	74LV165	96 PCS/tube	200 tube/box	19200 PCS/box	Dimensions of plastic enclosure: 5.0mm×4.4mm Pin spacing: 0.65mm

### Reel packing specifications:

Part number	Packaging form	Marking code	Reel quantity	Boxed reel quantity	Notes
AiP74LV165SA16.TR	SOP16	74LV165	4000 PCS/reel	8000 PCS/box	Dimensions of plastic enclosure: 10.0mm×3.9mm Pin spacing: 1.27mm
AiP74LV165VA16.TR	SSOP16	74LV165	2500 PCS/reel	5000 PCS/box	Dimensions of plastic enclosure: 6.2mm×5.3mm Pin spacing: 0.65mm
AiP74LV165TA16.TR	TSSOP16	74LV165	5000 PCS/reel	10000 PCS/box	Dimensions of plastic enclosure: 5.0mm×4.4mm Pin spacing: 0.65mm
AiP74LV165QK16.TR	VQFN16	74LV165	1500 PCS/reel	15000 PCS/box	Dimensions of plastic enclosure: 4.0mm×3.5mm Pin spacing: 0.5mm

Note: If the physical information is inconsistent with the ordering information, please refer to the actual product.



## 2、Block Diagram And Pin Description

### 2.1、Block Diagram

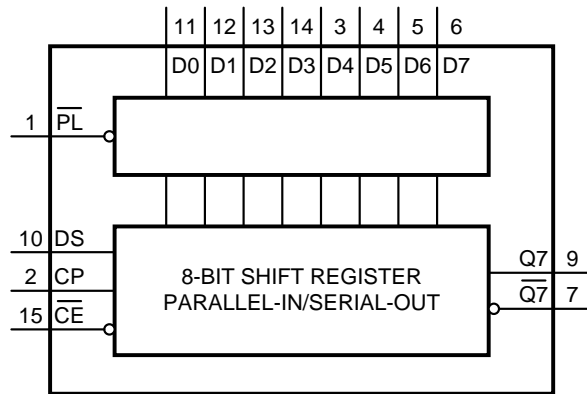

Figure 1. Functional diagram

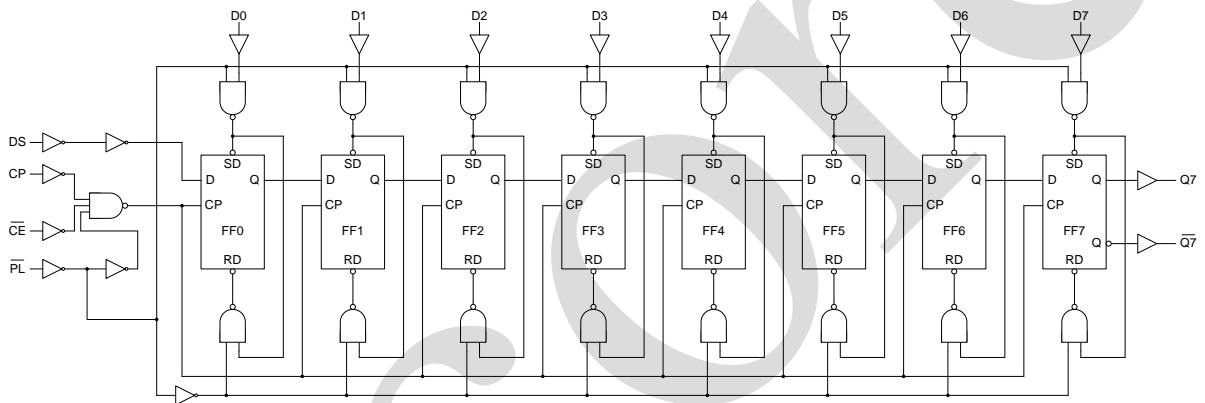

Figure 2. Logic diagram

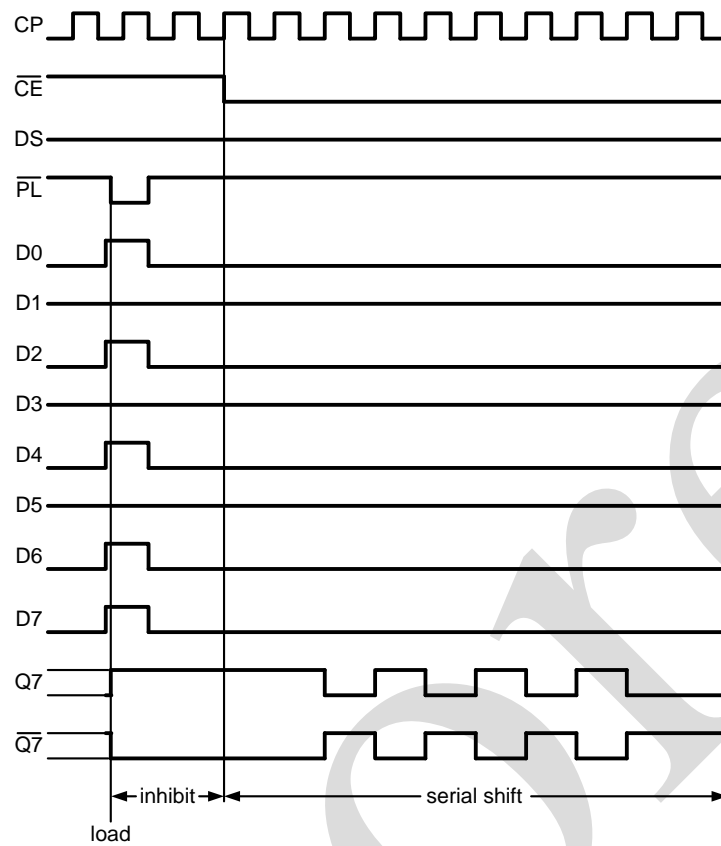
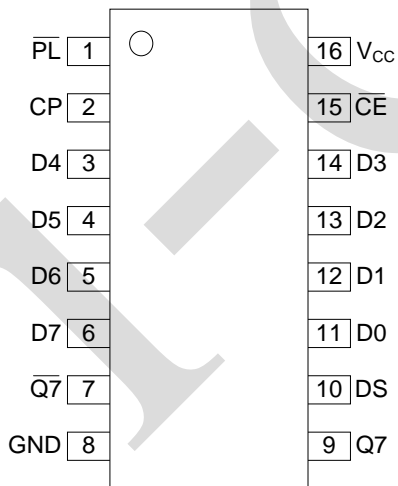
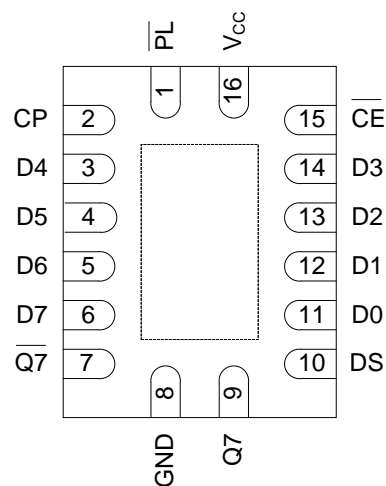

Figure 3. Timing diagram

## 2.2. Pin Configurations



SOP16/SSOP16/TSSOP16



VQFN16



## 2.3、Pin Description

Pin No.	Pin Name	Description
1	$\overline{\text{PL}}$	parallel enable input (active LOW)
2	CP	clock input (LOW-to-HIGH edge-triggered)
3	D4	parallel data input
4	D5	parallel data input
5	D6	parallel data input
6	D7	parallel data input
7	$\overline{\text{Q7}}$	complementary serial output from the last stage
8	GND	ground (0V)
9	Q7	serial output from the last stage
10	DS	serial data input
11	D0	parallel data input
12	D1	parallel data input
13	D2	parallel data input
14	D3	parallel data input
15	$\overline{\text{CE}}$	clock enable input (active LOW)
16	V <sub>CC</sub>	positive supply voltage

## 2.4、Function table

Operating mode	Input					Qn registers		Output	
	$\overline{\text{PL}}$	$\overline{\text{CE}}$	CP	DS	D0 to D7	Q0	Q0 to Q6	Q7	$\overline{\text{Q7}}$
parallel load	L	X	X	X	L	L	L to L	L	H
	L	X	X	X	H	H	H to H	H	L
serial shift	H	L	↑	l	X	L	q0 to q5	q6	$\overline{\text{q6}}$
	H	L	↑	h	X	J	q0 to q5	q6	$\overline{\text{q6}}$
hold “do nothing”	H	H	X	X	X	q0	q1 to q6	q7	q7

Note:

H=HIGH voltage level; L=LOW voltage level; X=don't care;

↑=LOW-to-HIGH clock transition;

h=HIGH voltage level one set-up time prior to the LOW-to-HIGH CP transition;

l=LOW voltage level one set-up time prior to the LOW-to-HIGH CP transition;

q=state of the referenced output one set-up time prior to the LOW-to-HIGH clock transition.



## 3、Electrical Parameter

### 3.1、Absolute Maximum Ratings

( $T_{amb}=25^{\circ}\text{C}$ , voltages are referenced to GND (ground=0V), unless otherwise specified)

Characteristic	Symbol	Conditions	Min.	Max.	Unit
supply voltage	$V_{CC}$	-	-0.5	+7.0	V
input voltage	$V_I$	-	-0.5	+7.0	V
input clamping current	$I_{IK}$	$V_I < -0.5\text{V}$ or $V_I > V_{CC} + 0.5\text{V}$	-	+20	mA
output clamping current	$I_{OK}$	$V_O > V_{CC}$ or $V_O < 0$	-	$\pm 50$	mA
output current	$I_O$	$V_O = -0.5\text{V}$ to $(V_{CC} + 0.5\text{V})$	-	$\pm 25$	mA
supply current	$I_{CC}$	-	-	+50	mA
ground current	$I_{GND}$	-	-50	-	mA
storage temperature	$T_{stg}$	-	-65	+150	$^{\circ}\text{C}$
total power dissipation	$P_{tot}$	-	-	500	mW
soldering temperature	$T_L$	10s	260		$^{\circ}\text{C}$

### 3.2、Recommended Operating Conditions

(Voltages are referenced to GND (ground=0V), unless otherwise specified.)

Parameter	Symbol	Conditions	Min.	Typ.	Max.	Unit
supply voltage	$V_{CC}$	-	1.0	3.3	5.5	V
input voltage	$V_I$	-	0	-	$V_{CC}$	V
output voltage	$V_O$	-	0	-	$V_{CC}$	V
ambient temperature	$T_{amb}$	-	-40	-	+125	$^{\circ}\text{C}$

### 3.3、Electrical Characteristics

#### 3.3.1、DC Characteristics 1

( $T_{amb}=-40^{\circ}\text{C}$  to  $+85^{\circ}\text{C}$ , voltages are referenced to GND (ground=0V), unless otherwise specified)

Parameter	Symbol	Conditions	Min.	Typ.	Max.	Unit	
HIGH-level input voltage	$V_{IH}$	$V_{CC}=1.2\text{V}$	0.9	-	-	V	
		$V_{CC}=2.3\text{V}$ to $2.7\text{V}$	1.4	-	-	V	
		$V_{CC}=2.7\text{V}$ to $3.6\text{V}$	2.0	-	-	V	
		$V_{CC}=4.5\text{V}$ to $5.5\text{V}$	$0.7V_{CC}$	-	-	V	
LOW-level input voltage	$V_{IL}$	$V_{CC}=1.2\text{V}$	-	-	0.3	V	
		$V_{CC}=2.3\text{V}$ to $2.7\text{V}$	-	-	0.6	V	
		$V_{CC}=2.7\text{V}$ to $3.6\text{V}$	-	-	0.8	V	
		$V_{CC}=4.5\text{V}$ to $5.5\text{V}$	-	-	$0.3V_{CC}$	V	
HIGH-level output voltage	$V_{OH}$	$V_I = V_{IH}$ or $V_{IL}$	$I_O = -100\mu\text{A}$ ; $V_{CC}=1.2\text{V}$	-	1.2	-	V
			$I_O = -100\mu\text{A}$ ; $V_{CC}=2.0\text{V}$	1.8	2.0	-	V
			$I_O = -100\mu\text{A}$ ; $V_{CC}=2.7\text{V}$	2.5	2.7	-	V
			$I_O = -100\mu\text{A}$ ; $V_{CC}=3.0\text{V}$	2.8	3.0	-	V
			$I_O = -100\mu\text{A}$ ; $V_{CC}=4.5\text{V}$	4.3	4.5	-	V
			$I_O = -6\text{mA}$ ; $V_{CC}=3.0\text{V}$	2.4	2.82	-	V
			$I_O = -12\text{mA}$ ; $V_{CC}=4.5\text{V}$	3.6	4.2	-	V
LOW-level output voltage	$V_{OL}$	$V_I = V_{IH}$ or $V_{IL}$	$I_O = 100\mu\text{A}$ ; $V_{CC}=1.2\text{V}$	-	0	-	V
			$I_O = 100\mu\text{A}$ ; $V_{CC}=2.0\text{V}$	-	0	0.2	V
			$I_O = 100\mu\text{A}$ ; $V_{CC}=2.7\text{V}$	-	0	0.2	V



			$I_O=100\mu A; V_{CC}=3.0V$	-	0	0.2	V
			$I_O=100\mu A; V_{CC}=4.5V$	-	0	0.2	V
			$I_O=6mA; V_{CC}=3.0V$	-	0.25	0.4	V
			$I_O=12mA; V_{CC}=4.5V$	-	0.35	0.55	V
input leakage current	$I_I$	$V_I=V_{CC}$ or GND; $V_{CC}=5.5V$		-	-	$\pm 1$	$\mu A$
power-off leakage current	$I_{OFF}$	$V_I$ or $V_O=5.5V; V_{CC}=0V$		-	-	$\pm 5$	$\mu A$
supply current	$I_{CC}$	$V_I=V_{CC}$ or GND; $I_O=0A; V_{CC}=5.5V$		-	-	20	$\mu A$
additional supply current	$\Delta I_{CC}$	per input; $V_I=V_{CC}-0.6V;$ $V_{CC}=2.7V$ to $3.6V$		-	-	500	$\mu A$

### 3.3.2、DC Characteristics 2

( $T_{amb}=-40^{\circ}C$  to  $+125^{\circ}C$ , voltages are referenced to GND (ground=0V), unless otherwise specified)

Parameter	Symbol	Conditions	Min.	Typ.	Max.	Unit	
HIGH-level input voltage	$V_{IH}$	$V_{CC}=1.2V$	0.9	-	-	V	
		$V_{CC}=2.3V$ to $2.7V$	1.4	-	-	V	
		$V_{CC}=2.7V$ to $3.6V$	2.0	-	-	V	
		$V_{CC}=4.5V$ to $5.5V$	$0.7V_{CC}$	-	-	V	
LOW-level input voltage	$V_{IL}$	$V_{CC}=1.2V$	-	-	0.3	V	
		$V_{CC}=2.3V$ to $2.7V$	-	-	0.6	V	
		$V_{CC}=2.7V$ to $3.6V$	-	-	0.8	V	
		$V_{CC}=4.5V$ to $5.5V$	-	-	$0.3V_{CC}$	V	
HIGH-level output voltage	$V_{OH}$	$V_I=V_{IH}$ or $V_{IL}$	$I_O=-100\mu A; V_{CC}=2.0V$	1.8	-	-	V
			$I_O=-100\mu A; V_{CC}=2.7V$	2.5	-	-	V
			$I_O=-100\mu A; V_{CC}=3.0V$	2.8	-	-	V
			$I_O=-100\mu A; V_{CC}=4.5V$	4.3	-	-	V
			$I_O=-6mA; V_{CC}=3.0V$	2.2	-	-	V
			$I_O=-12mA; V_{CC}=4.5V$	3.5	-	-	V
LOW-level output voltage	$V_{OL}$	$V_I=V_{IH}$ or $V_{IL}$	$I_O=100\mu A; V_{CC}=2.0V$	1.8	-	0.2	V
			$I_O=100\mu A; V_{CC}=2.7V$	2.5	-	0.2	V
			$I_O=100\mu A; V_{CC}=3.0V$	2.8	-	0.2	V
			$I_O=100\mu A; V_{CC}=4.5V$	4.3	-	0.2	V
			$I_O=6mA; V_{CC}=3.0V$	-	-	0.5	V
			$I_O=12mA; V_{CC}=4.5V$	-	-	0.65	V
input leakage current	$I_I$	$V_I=V_{CC}$ or GND; $V_{CC}=5.5V$		-	-	$\pm 1$	$\mu A$
power-off leakage current	$I_{OFF}$	$V_I$ or $V_O=5.5V; V_{CC}=0V$		-	-	$\pm 10$	$\mu A$
supply current	$I_{CC}$	$V_I=V_{CC}$ or GND; $I_O=0A; V_{CC}=5.5V$		-	-	160	$\mu A$
additional supply current	$\Delta I_{CC}$	per input; $V_I=V_{CC}-0.6V;$ $V_{CC}=2.7V$ to $3.6V$		-	-	850	$\mu A$



### 3.3.3、AC Characteristics 1

( $T_{amb} = -40^{\circ}\text{C}$  to  $+85^{\circ}\text{C}$ , GND=0V, unless otherwise specified)

Parameter	Symbol	Conditions	Min.	Typ.	Max.	Unit	
propagation delay	$t_{PHL}/t_{PLH}$	$\overline{CE}$ , CP to Q7, $\overline{Q7}$ ; see Figure 5 and Figure 6	$V_{CC}=1.2\text{V}$	-	115	-	ns
			$V_{CC}=2.0\text{V}$	-	38	61	ns
			$V_{CC}=2.7\text{V}$	-	27	43	ns
			$V_{CC}=3.0\text{V}$ to $3.6\text{V}$	-	22	36	ns
			$V_{CC}=3.3\text{V}$ ; $C_L=15\text{pF}$	-	18	-	ns
			$V_{CC}=4.5\text{V}$ to $5.5\text{V}$	-	15	24	ns
		$\overline{PL}$ to Q7, $\overline{Q7}$ ; see Figure 6	$V_{CC}=1.2\text{V}$	-	110	-	ns
			$V_{CC}=2.0\text{V}$	-	35	56	ns
			$V_{CC}=2.7\text{V}$	-	24	39	ns
			$V_{CC}=3.0\text{V}$ to $3.6\text{V}$	-	20	33	ns
			$V_{CC}=3.3\text{V}$ ; $C_L=15\text{pF}$	-	18	-	ns
			$V_{CC}=4.5\text{V}$ to $5.5\text{V}$	-	14	22	ns
		D7 to Q7, $\overline{Q7}$ ; see Figure 7	$V_{CC}=1.2\text{V}$	-	90	-	ns
			$V_{CC}=2.0\text{V}$	-	28	45	ns
			$V_{CC}=2.7\text{V}$	-	20	32	ns
			$V_{CC}=3.0\text{V}$ to $3.6\text{V}$	-	17	27	ns
			$V_{CC}=3.3\text{V}$ ; $C_L=15\text{pF}$	-	14	-	ns
			$V_{CC}=4.5\text{V}$ to $5.5\text{V}$	-	11	18	ns
pulse width	$t_w$	CP input HIGH to LOW; see Figure 5	$V_{CC}=2.0\text{V}$	34	10	-	ns
			$V_{CC}=2.7\text{V}$	25	8	-	ns
			$V_{CC}=3.0\text{V}$ to $3.6\text{V}$	20	7	-	ns
			$V_{CC}=4.5\text{V}$ to $5.5\text{V}$	15	5	-	ns
		$\overline{PL}$ input LOW; see Figure 6	$V_{CC}=2.0\text{V}$	34	10	-	ns
			$V_{CC}=2.7\text{V}$	25	8	-	ns
			$V_{CC}=3.0\text{V}$ to $3.6\text{V}$	20	7	-	ns
			$V_{CC}=4.5\text{V}$ to $5.5\text{V}$	15	5	-	ns
recovery time	$t_{rec}$	$\overline{PL}$ to CP, $\overline{CE}$ ; see Figure 6	$V_{CC}=1.2\text{V}$	-	40	-	ns
			$V_{CC}=2.0\text{V}$	24	15	-	ns
			$V_{CC}=2.7\text{V}$	18	11	-	ns
			$V_{CC}=3.0\text{V}$ to $3.6\text{V}$	17	10	-	ns
			$V_{CC}=4.5\text{V}$ to $5.5\text{V}$	12	7	-	ns
set-up time	$t_{su}$	DS to CP, $\overline{CE}$ ; see Figure 8	$V_{CC}=1.2\text{V}$	-	-8	-	ns
			$V_{CC}=2.0\text{V}$	22	-2	-	ns
			$V_{CC}=2.7\text{V}$	16	-1	-	ns
			$V_{CC}=3.0\text{V}$ to $3.6\text{V}$	13	-1	-	ns
			$V_{CC}=4.5\text{V}$ to $5.5\text{V}$	9	0	-	ns
		$\overline{CE}$ to CP, CP to $\overline{CE}$ ; see Figure 8	$V_{CC}=1.2\text{V}$	-	20	-	ns
			$V_{CC}=2.0\text{V}$	22	7	-	ns
			$V_{CC}=2.7\text{V}$	16	5	-	ns
			$V_{CC}=3.0\text{V}$ to $3.6\text{V}$	13	4	-	ns
			$V_{CC}=4.5\text{V}$ to $5.5\text{V}$	9	3	-	ns
		Dn to $\overline{PL}$ ; see Figure 9	$V_{CC}=1.2\text{V}$	-	25	-	ns
			$V_{CC}=2.0\text{V}$	22	8	-	ns



			$V_{CC}=2.7V$	16	6	-	ns
			$V_{CC}=3.0V$ to $3.6V$	13	5	-	ns
			$V_{CC}=4.5V$ to $5.5V$	9	4	-	ns
hold time	$t_h$	DS to CP, $\overline{CE}$ ; Dn to $\overline{PL}$ ; see Figure 8 and 9	$V_{CC}=1.2V$	-	20	-	ns
			$V_{CC}=2.0V$	22	7	-	ns
			$V_{CC}=2.7V$	16	5	-	ns
			$V_{CC}=3.0V$ to $3.6V$	13	4	-	ns
			$V_{CC}=4.5V$ to $5.5V$	9	3	-	ns
		$\overline{CE}$ to CP, CP to $\overline{CE}$ ; see Figure 8	$V_{CC}=1.2V$	-	-30	-	ns
			$V_{CC}=2.0V$	5	-8	-	ns
			$V_{CC}=2.7V$	5	-6	-	ns
			$V_{CC}=3.0V$ to $3.6V$	5	-5	-	ns
			$V_{CC}=4.5V$ to $5.5V$	5	-4	-	ns
maximum frequency	$f_{max}$	see Figure 5	$V_{CC}=2.0V$	14	-	-	MHz
			$V_{CC}=2.7V$	19	-	-	MHz
			$V_{CC}=3.0V$ to $3.6V$	24	-	-	MHz
			$V_{CC}=3.3V$ ; $C_L=15pF$	-	-	-	MHz
			$V_{CC}=4.5V$ to $5.5V$	36	-	-	MHz

### 3.3.4、AC Characteristics 2

( $T_{amb} = -40^{\circ}C$  to  $+125^{\circ}C$ , GND=0V, unless otherwise specified)

Parameter	Symbol	Conditions	Min.	Typ.	Max.	Unit	
propagation delay	$t_{PHL}/t_{PLH}$	$\overline{CE}$ , CP to Q7, $\overline{Q7}$ ; see Figure 5 and Figure 6	$V_{CC}=2.0V$	-	-	76	ns
			$V_{CC}=2.7V$	-	-	54	ns
			$V_{CC}=3.0V$ to $3.6V$	-	-	45	ns
			$V_{CC}=4.5V$ to $5.5V$	-	-	30	ns
		$\overline{PL}$ to Q7, $\overline{Q7}$ ; see Figure 6	$V_{CC}=2.0V$	-	-	70	ns
			$V_{CC}=2.7V$	-	-	49	ns
			$V_{CC}=3.0V$ to $3.6V$	-	-	41	ns
		D7 to Q7, $\overline{Q7}$ ; see Figure 7	$V_{CC}=4.5V$ to $5.5V$	-	-	27	ns
			$V_{CC}=2.0V$	-	-	56	ns
			$V_{CC}=2.7V$	-	-	40	ns
$V_{CC}=3.0V$ to $3.6V$	-		-	33	ns		
pulse width	$t_w$	CP input HIGH to LOW; see Figure 5	$V_{CC}=4.5V$ to $5.5V$	-	-	22	ns
			$V_{CC}=2.0V$	41	-	-	ns
			$V_{CC}=2.7V$	30	-	-	ns
			$V_{CC}=3.0V$ to $3.6V$	24	-	-	ns
		$\overline{PL}$ input LOW; see Figure 6	$V_{CC}=4.5V$ to $5.5V$	18	-	-	ns
			$V_{CC}=2.0V$	41	-	-	ns
			$V_{CC}=2.7V$	30	-	-	ns
			$V_{CC}=3.0V$ to $3.6V$	24	-	-	ns
recovery time	$t_{rec}$	$\overline{PL}$ to CP, $\overline{CE}$ ; see Figure 6	$V_{CC}=4.5V$ to $5.5V$	15	-	-	ns
			$V_{CC}=2.0V$	30	-	-	ns
			$V_{CC}=2.7V$	23	-	-	ns
			$V_{CC}=3.0V$ to $3.6V$	21	-	-	ns



set-up time	$t_{su}$	DS to CP, $\overline{CE}$ ; see Figure 8	$V_{CC}=2.0V$	26	-	-	ns
			$V_{CC}=2.7V$	19	-	-	ns
			$V_{CC}=3.0V$ to 3.6V	15	-	-	ns
			$V_{CC}=4.5V$ to 5.5V	10	-	-	ns
		$\overline{CE}$ to CP, CP to $\overline{CE}$ ; see Figure 8	$V_{CC}=2.0V$	26	-	-	ns
			$V_{CC}=2.7V$	19	-	-	ns
			$V_{CC}=3.0V$ to 3.6V	15	-	-	ns
			$V_{CC}=4.5V$ to 5.5V	10	-	-	ns
		Dn to $\overline{PL}$ ; see Figure 9	$V_{CC}=2.0V$	26	-	-	ns
			$V_{CC}=2.7V$	19	-	-	ns
			$V_{CC}=3.0V$ to 3.6V	15	-	-	ns
			$V_{CC}=4.5V$ to 5.5V	10	-	-	ns
hold time	$t_h$	DS to CP, $\overline{CE}$ ; Dn to $\overline{PL}$ ; see Figure 8 and 9	$V_{CC}=2.0V$	26	-	-	ns
			$V_{CC}=2.7V$	19	-	-	ns
			$V_{CC}=3.0V$ to 3.6V	15	-	-	ns
			$V_{CC}=4.5V$ to 5.5V	10	-	-	ns
		$\overline{CE}$ to CP, CP to $\overline{CE}$ ; see Figure 8	$V_{CC}=2.0V$	5	-	-	ns
			$V_{CC}=2.7V$	5	-	-	ns
			$V_{CC}=3.0V$ to 3.6V	5	-	-	ns
			$V_{CC}=4.5V$ to 5.5V	5	-	-	ns
maximum frequency	$f_{max}$	see Figure 5	$V_{CC}=2.0V$	12	-	-	MHz
			$V_{CC}=2.7V$	16	-	-	MHz
			$V_{CC}=3.0V$ to 3.6V	20	-	-	MHz
			$V_{CC}=4.5V$ to 5.5V	30	-	-	MHz



## 4、Testing Circuit

### 4.1、AC Testing Circuit

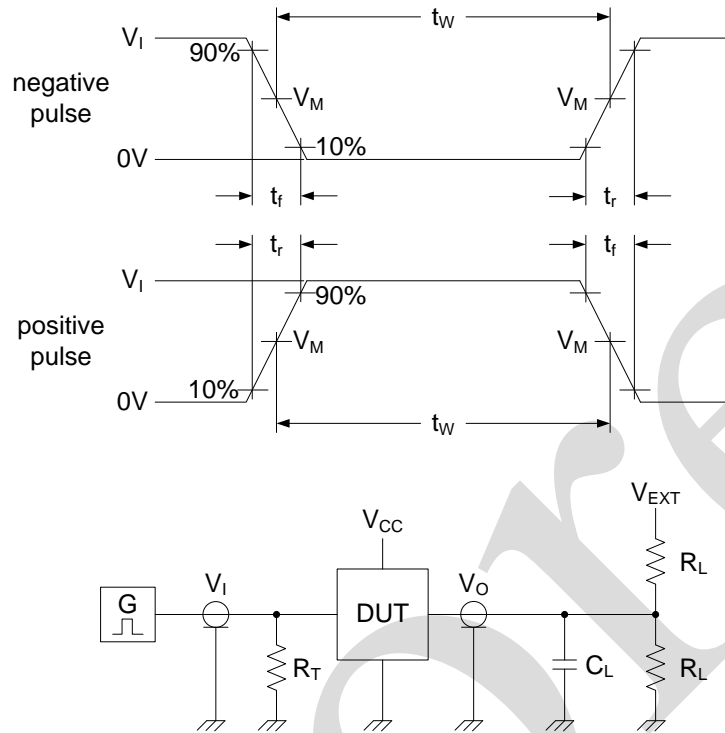

Figure 4. Test circuit for measuring switching times

Definitions for test circuit:

$R_L$ =Load resistance.

$C_L$ =Load capacitance including jig and probe capacitance.

$R_T$ =Termination resistance should be equal to output impedance  $Z_o$  of the pulse generator.

$V_{EXT}$ =External voltage for measuring switching times.

### 4.2、AC Testing Waveforms

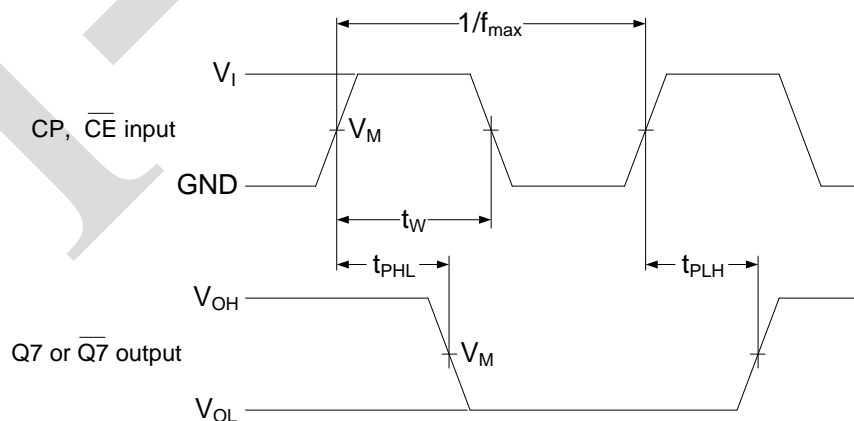

Figure 5. Clock pulse (CP) and clock enable ( $\overline{CE}$ ) to output (Q7 or  $\overline{Q7}$ ) propagation delays, clock pulse width and maximum clock frequency

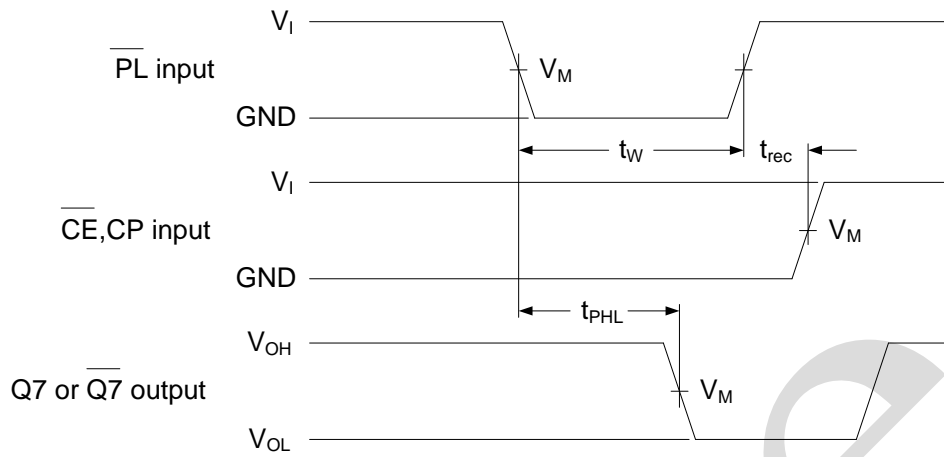

Figure 6. Parallel load ( $\overline{PL}$ ) pulse width, parallel load to output ( $Q7$  or  $\overline{Q7}$ ) propagation delays, parallel load to clock (CP) and clock enable ( $\overline{CE}$ ) recovery time

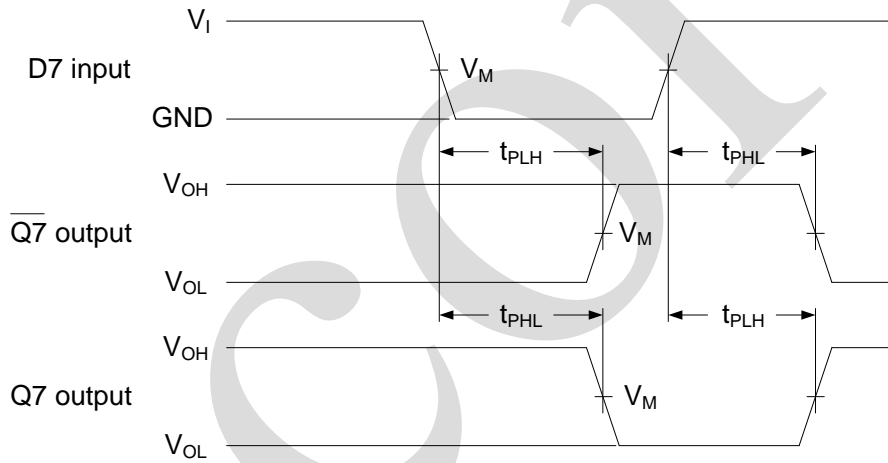
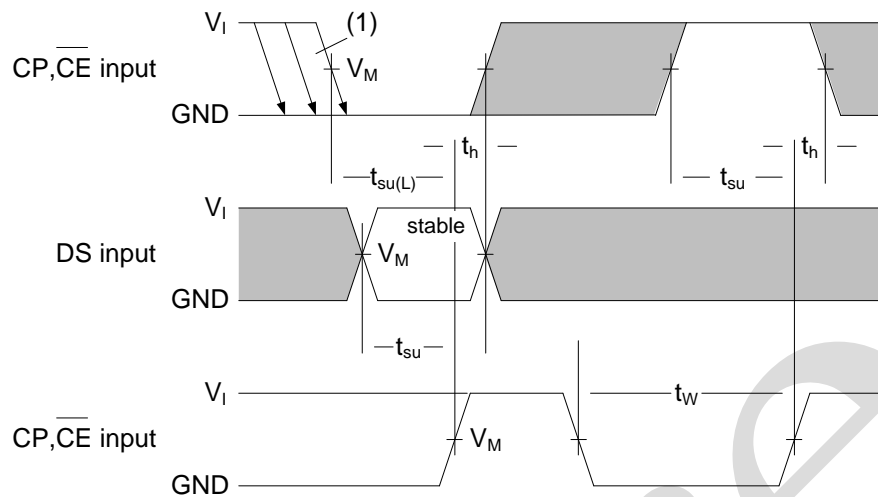

Figure 7. Data input ( $D_n$ ) to output ( $Q7$  or  $\overline{Q7}$ ) propagation delays when PL is LOW



Note:

(1) CE may change only from HIGH-to-LOW while CP is LOW. The shaded areas indicate when the input is permitted to change for predictable output performance.

Figure 8. Set-up and hold times

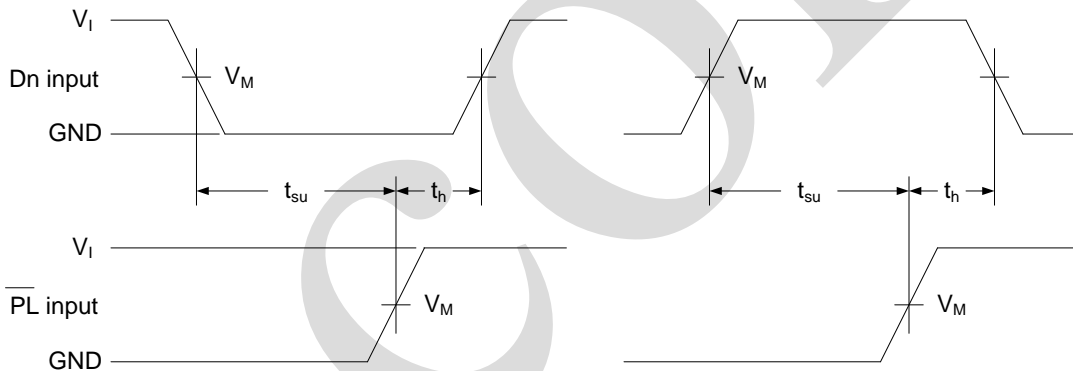

Figure 9. Set-up and hold times from the data inputs (Dn) to the parallel load input ( $\overline{PL}$ )

### 4.3. Measurement Points

Supply voltage	Input	Output
$V_{CC}$	$V_M$	$V_M$
<2.7V	$0.5 \times V_{CC}$	$0.5 \times V_{CC}$
2.7V to 3.6V	1.5V	1.5V
$\geq 4.5V$	$0.5 \times V_{CC}$	$0.5 \times V_{CC}$

### 4.4. Test Data

Supply voltage	Input		Load		Test
$V_{CC}$	$V_I$	$t_r, t_f$	$C_L$	$R_L$	$t_{PHL}, t_{PLH}$
<2.7V	$V_{CC}$	$\leq 3.0ns$	50pF	1k $\Omega$	open
2.7V to 3.6V	2.7V	$\leq 3.0ns$	50pF, 15pF	1k $\Omega$	open
$\geq 4.5V$	$V_{CC}$	$\leq 3.0ns$	50pF	1k $\Omega$	open



## 5、Package Information

### 5.1、SOP16

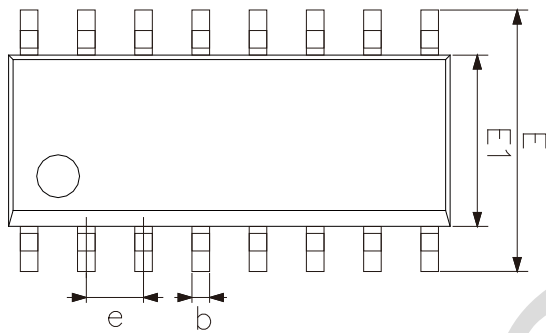
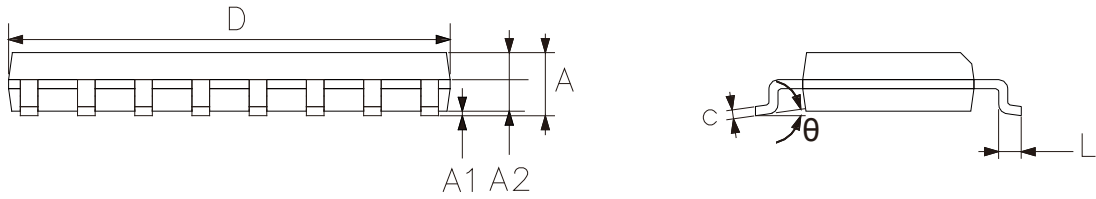

2023/12/A	Dimensions In Millimeters	
Symbol	Min.	Max.
A	1.35	1.80
A1	0.10	0.25
A2	1.25	1.55
b	0.33	0.51
c	0.19	0.25
D	9.50	10.10
E	5.80	6.30
E1	3.70	4.10
e	1.27	
L	0.35	0.89
$\theta$	0°	8°



## 5.2、SSOP16

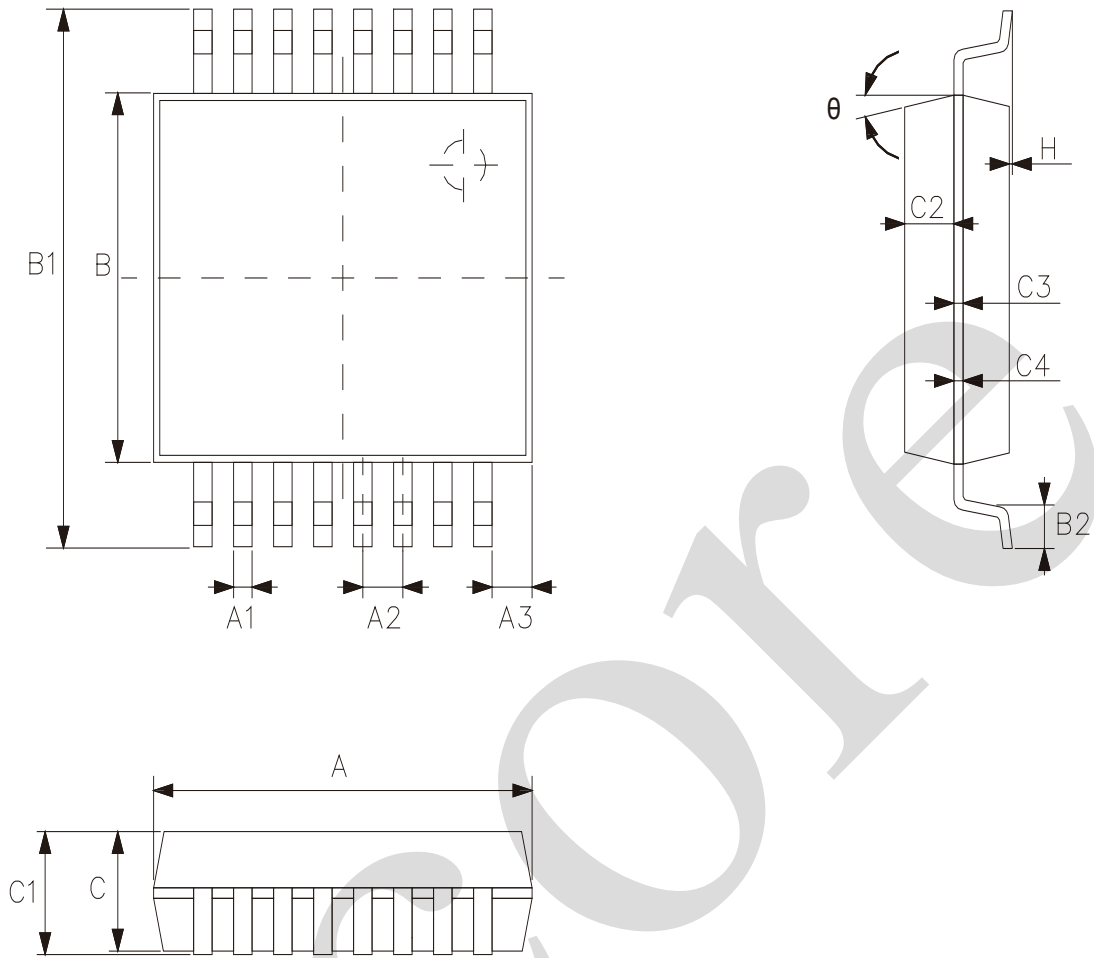

2023/12/A		
Dimensions In Millimeters		
Symbol	Min	Max
A	6.15	6.25
A1	0.30	
A2	0.65	
A3	0.675	
B	5.25	5.35
B1	7.65	7.95
B2	0.60	0.80
C	1.70	1.80
C1	1.75	1.95
C2	0.80	
C3	0.15	
C4	0.17	
H	0.05	0.15
$\theta$	0°	8°



## 5.3、TSSOP16

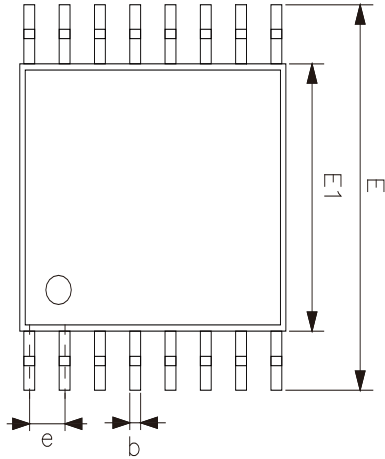
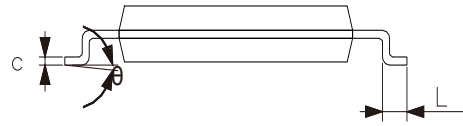
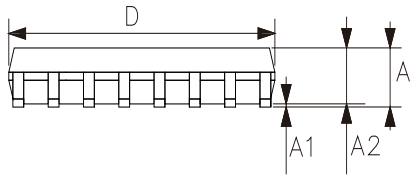

2023/12/A	Dimensions In Millimeters	
Symbol	Min	Max
A	—	1.20
A1	0.05	0.15
A2	0.80	1.05
b	0.19	0.30
c	0.09	0.20
D	4.90	5.10
E1	4.30	4.50
E	6.20	6.60
e	0.65	
L	0.45	0.75
$\theta$	0°	8°



## 5.4、VQFN16

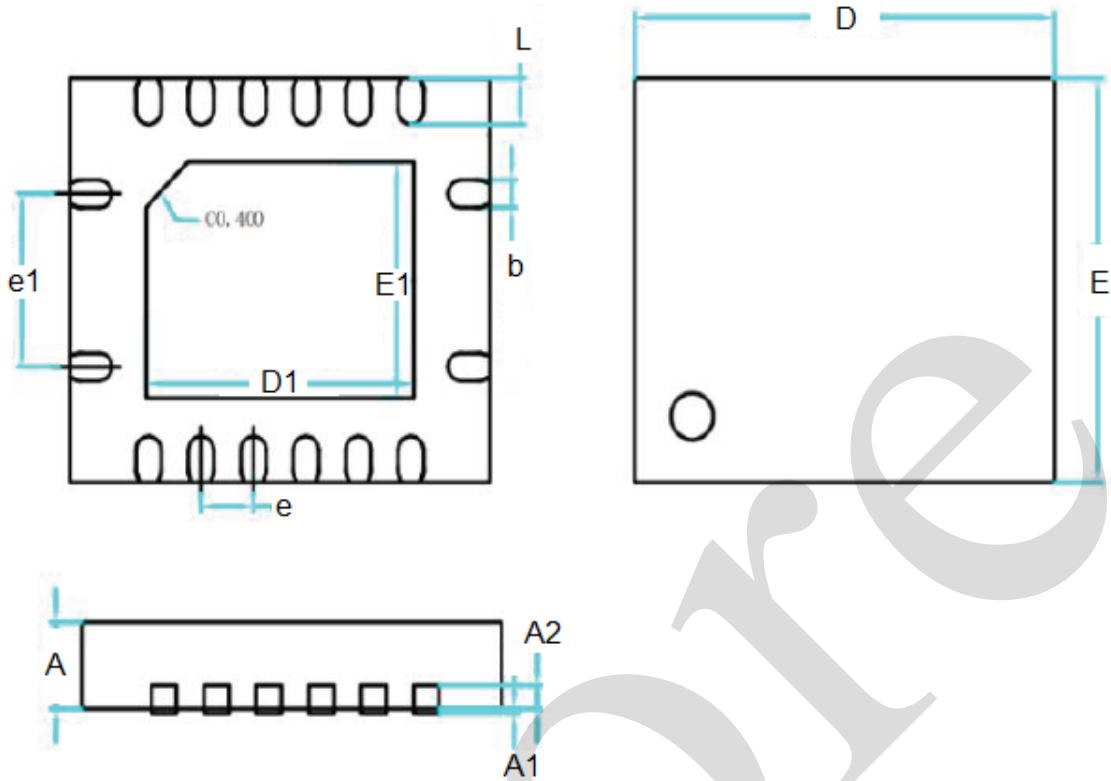

2023/12/A	Dimensions In Millimeters	
	Min	Max
A		0.75
A1		0.05
A2		0.203
b	0.215	0.265
D		4.00
D1	2.525	2.575
E		3.50
E1	2.025	2.075
e	0.475	0.525
e1	1.475	1.525
L		0.40



## 6、 Statements And Notes

### 6.1、 The name and content of Hazardous substances or Elements in the product

Part name	Hazardous substances or Elements									
	Lead and lead compounds	Mercury and mercury compounds	Cadmium and cadmium compounds	Hexavalent chromium compounds	Polybrominated biphenyls	Polybrominated biphenyl ethers	Dibutyl phthalate	Butylbenzyl phthalate	Di-2-ethylhexyl phthalate	Diisobutyl phthalate
Lead frame	○	○	○	○	○	○	○	○	○	○
Plastic resin	○	○	○	○	○	○	○	○	○	○
Chip	○	○	○	○	○	○	○	○	○	○
The lead	○	○	○	○	○	○	○	○	○	○
Plastic sheet installed	○	○	○	○	○	○	○	○	○	○
explanation	○: Indicates that the content of hazardous substances or elements in the detection limit of the following the SJ/T11363-2006 standard. ×: Indicates that the content of hazardous substances or elements exceeding the SJ/T11363-2006 Standard limit requirements.									

### 6.2、 Notes

We recommend you to read this chapter carefully before using this product.

The information in this chapter is provided for reference only and i-Core disclaims any express or implied warranties, including but not limited to applicability, special application or non-infringement of third party rights.

This product is not suitable for critical equipment such as life-saving, life-sustaining or safety equipment. It is also not suitable for applications that may result in personal injury, death, or serious property or environmental damage due to product malfunction or failure. I-Core will not be liable for any damages incurred by the customers at their own risk for such applications.

The customer is responsible for conducting all necessary tests i-Core's application to avoid failure in the application or the application of the customer's third party users. I-Core does not accept any liability.

The Company reserves the right to change or improve the information published in this chapter at any time. The information in this chapter are subject to change without notice. We recommend the customer to consult our sales staff before purchasing.

Please obtain related materials form i-Core's regular channels and we are not responsible for its content if it is provided by sources other than our company.

In case of any conflict between the Chinese and English version, the version is subject to the Chinese one.